



RHO

Elektronik GmbH

THETA

2-Band Precision Direction Finder

RT-300



The complete solution
for **Safety** and
Communication



The RT-300 is an all-purpose dual-band direction finder that receives not only emergency signals on the 121.5 MHz frequency but also voice communication on the marine band. Developed for mobile operation at sea or on land as well as for stationary landside operation, e.g., vessel traffic service, the RT-300 is an SAR and communication direction finder as well as a navigation aid all in one.

The 121.5 MHz frequency is automatically monitored while the marine band is in use. The RT-300 also sets new benchmarks in terms of reception sensitivity and directional precision. Sophisticated algorithms provide fast, stable display of data.

Features

- Completely automatic operation
- Very high receiver sensitivity to permit detection of very weak or remote signals
- Availability of all 88 channels (156.000 to 162.025 MHz) of the marine band
- Availability of the 121.500 MHz emergency frequency as well as 198 channels for training purposes in the air band
- Automatic monitoring of the emergency frequency while using the marine band
- Selection of duplex channels (coast and ship channels) possible
- Bearing information is displayed on a graphic LCD and a circular LED direction indicator
- All relevant information shown on the LCD
- No leg error if external gyro or compass information is connected
- Internal magnet compass (option) eliminates leg error
- Selective alarm function to prevent false alarms
- Automatic squelch adjustment
- Compact and robust construction ensures exceptional reliability
- All DF components are waterproof (IP 67)
- Easy to install: no RF cables required
- Integration into existing system possible with NMEA, RS-232 or RS-485 interface
- Special antenna/receiver models optionally available for different frequencies
- Illuminated display and keys to permit use at night

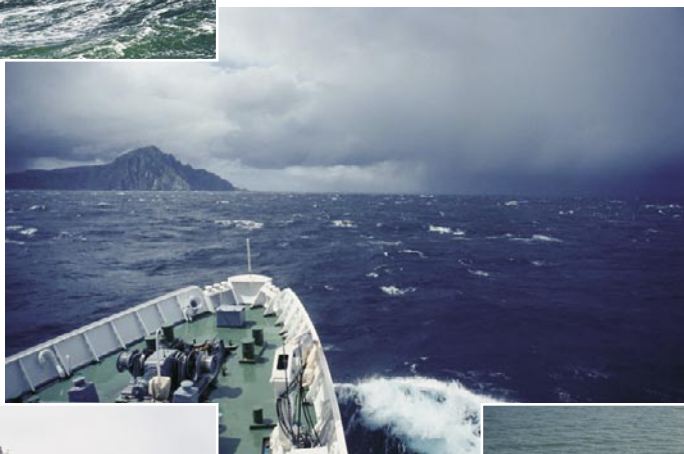

The RT-300 is an SAR and communication direction finder plus navigation aid in a single unit. The RT-300 is used by professional SAR organizations, piloting authorities and vessel traffic services.

The system is used as a navigation aid and an MOB device to guarantee crew safety on commercial vessels.

Technical data

Method of bearing:	Doppler principle (3 kHz rotational frequency, right / left rotation)		
Bearing accuracy ¹ :	Better than $\pm 5^\circ$		
Displayed resolution:	Digital display: 1° , LED circle: 10° , 0.5° at serial NMEA output		
Bearing reference:	Relative to antenna orientation, magnetic or true north		
Internal resolution:	0.5°		
Sensitivity for system accuracy of 5° :	RF voltage at receiver input (50Ω): ≤ 50 nV (VHF + UHF) Electrical field (radiated sensitivity): 121.500 MHz: ≤ 0.5 $\mu\text{V/m}$ 156.800 MHz: ≤ 1.5 $\mu\text{V/m}$		
Frequency stability:	± 2.0 ppm ($\Delta f/f = \pm 2 \times 10^{-6}$) (at temperatures from -30 °C to $+80$ °C)		
Receiving bands:	2		
Receiving frequencies: (or see identification plate for special customer-specific options)	RT-300-VS VHF air band: 118.000 to 121.500 to 124.000 MHz VHF marine band: 156.000 to 156.800 to 162.025 MHz (marine, channels 1 – 88) RT-300-VU VHF air band: 118.000 to 121.500 to 124.000 MHz UHF air band: 241.000 to 243.000 to 245.000 MHz		
Frequency increments:	25 kHz		
Bearable modulation:	A3E, F3E, A3X (PLB modulation), bearing largely independent of modulation		
Polarization:	Vertical		
Polarization error:	$\leq 5^\circ$ at 60° field vector rotation		
Garbling cone:	Approx. 30° to the vertical		
Response time ² :	≤ 100 ms (with sufficient reception field strength)		
User interface:	LC graphic display 98 x 32 pixels backlight 13 illuminated keys 36 LED circle for bearing display Freely adjustable dimming of LCD brightness, LCD backlight, key illumination and LED circle illumination		
Supply voltage:	12 V to 28 V DC		
Power consumption:	Supply voltage	12 V	28 V
	Standby	350 mA (4.2 W)	250 mA (7.0 W)
	Av. without ext. speaker	400 mA (4.8 W)	300 mA (8.4 W)
	Av. with ext. speaker	600 mA (7.2 W)	400 mA (11.2 W)
	Max. without ext. speaker	450 mA (5.4 W)	350 mA (9.8 W)
	Max. with ext. speaker	800 mA (9.6 W)	600 mA (16.8 W)
Audio out:	Max. 1.5 W at 4Ω ($U_{pp,max} = 10$ V)		
Interface:	RS-232, NMEA (RS-422 with galvanic isolation of input), RS-485, relay contact (switching on if alarm is detected), input for self-bearing suppression		

¹ With undisturbed wave field and sufficient field strength. Measured by changing the angle of incidence with the antenna rotating on a revolving table in order to eliminate environmental influences on the results.

² Very weak signals can increase response time considerably!

Mechanical data

Weight:	Display Control Unit (DCU): approx. 700 g Antenna Unit (AU): approx. 1400 g
Operating temperature:	-20 °C to +60 °C
Storage temperature:	-50 °C to +70 °C
Ingress protection:	IP 67 (The use of the mast sealing kit is recommended to protect the antenna connector against moisture.)

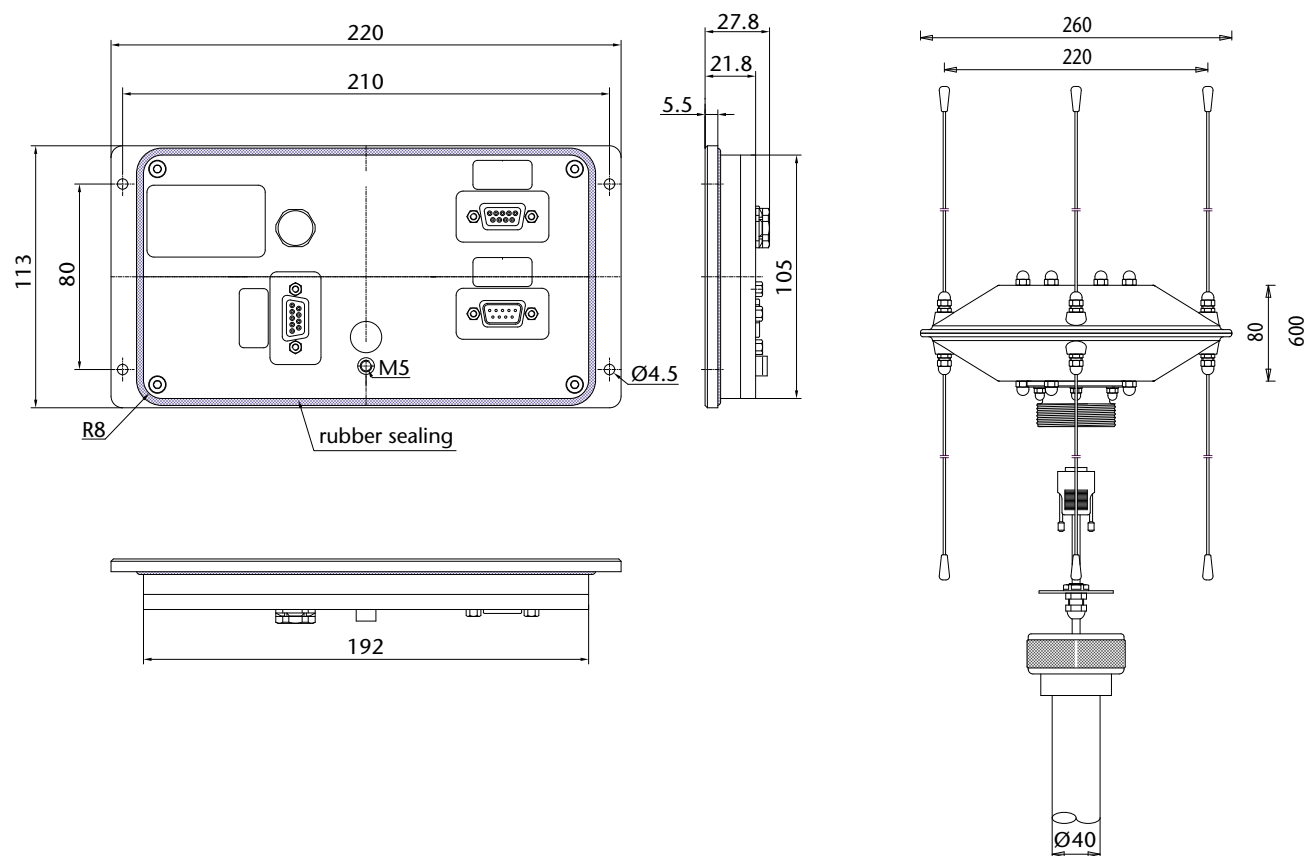

All product specifications subject to change without notice.

RHOTHETA Elektronik GmbH
Dr.-Ingeborg-Haeckel-Str. 2
82418 Murnau
Germany

E-Mail: email@rhotheta.de
Internet: www.rhotheta.com

Tel.: +49 8841 4879 - 0
Fax: +49 8841 4879 - 15

Coordinates:
N 47.6842° / E 11.1982° / (WGS 84)